

# छत्तीसगढ़ राज्य अक्षय ऊर्जा विकास अभिकरण (क्रेडा)

प्रधान कार्यालय, ऊर्जा शिक्षा उद्यान के पास  
व्ही.आई.पी. रोड (एयरपोर्ट रोड), फुंडहर रायपुर, (छ.ग.)

Tel.: 8370009925, 8370009923, Email :- contact.creda@gov.in, Website :- www.creda.co.in



क्रमांक 2623 / क्रेडा / नि.प्रको. / 2020-21

रायपुर, दिनांक: 17.06.2020

## //CORRIGENDUM For T.No. 2065, dated 09-06-2020//

In continuation of Tender No. 2065, dated 09-06-2020 for STANDARDISATION OF RATES FOR SUPPLY AND INSTALLATION OF SOLAR DRINKING WATER PUMPING SYSTEMS (SPV DUAL PUMPS) OF CAPACITY 1200Wp/09M & 12M, HEIGHT STAGING/10KL TANK, WITH FIVE YEARS ON SITE AND UNCONDITIONAL WARRANTY ANYWHERE IN STATE OF CHHATTISGARH. There is the change in Structural Drawing as follows:-

SN	Particulars	Existing	Amendment
1	Drawing of Solar Dual Pump of 09M Staging (with one Joint) & 10KL Tank	Point No. 17 Page No. 41 to 43 of Annexure -II	Annexure II (Total Pages- 03 i.e. page no. 1, 2, 3 as attached)
2	New Drawing for Solar Dual Pump of 09M Staging (without joint) & 10KL Tank	Not Available	(Total additional Pages- 03 i.e. page no. 4, 5, 6 as attached)
3	Drawing of Solar Dual Pump of 12M Staging (with one Joint) & 10KL Tank	Point No. 18 Page No. 53 of Annexure-III	Annexure III (Total Page- 01 i.e. page no. 7 as attached)
4	New Drawing for Foundation details of Solar Dual Pump of 12M Staging/10KL Tank	Not Available	(Total additional Pages- 01 i.e. page no. 8 as attached)

(Sanjeev Jain)  
Chief Engineer

17.

(1)

Annexure-II

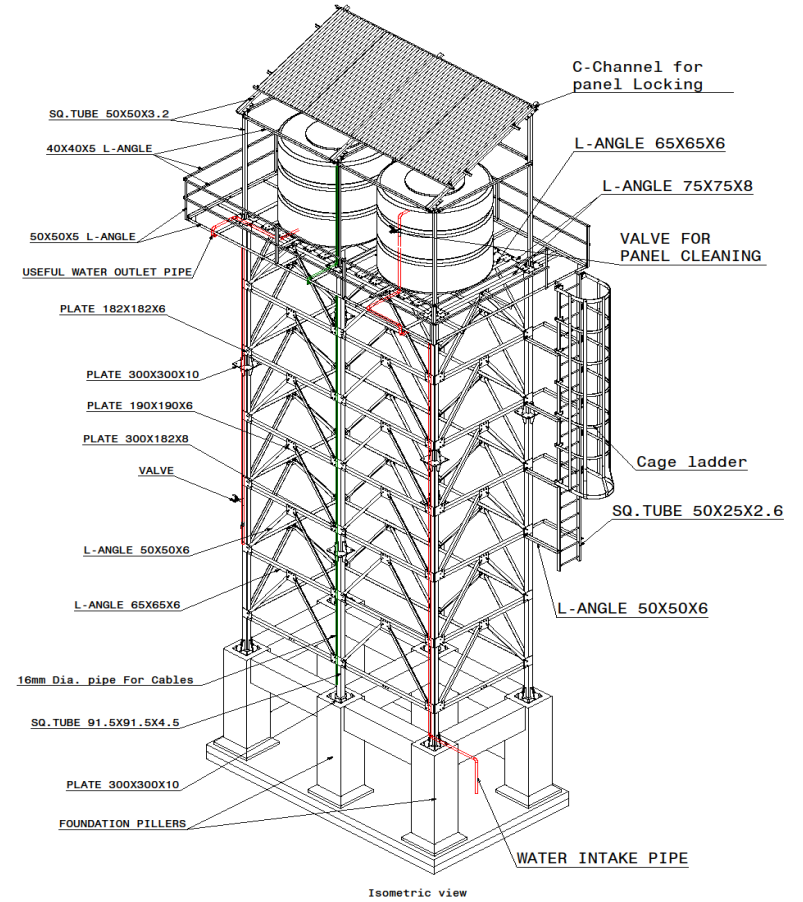
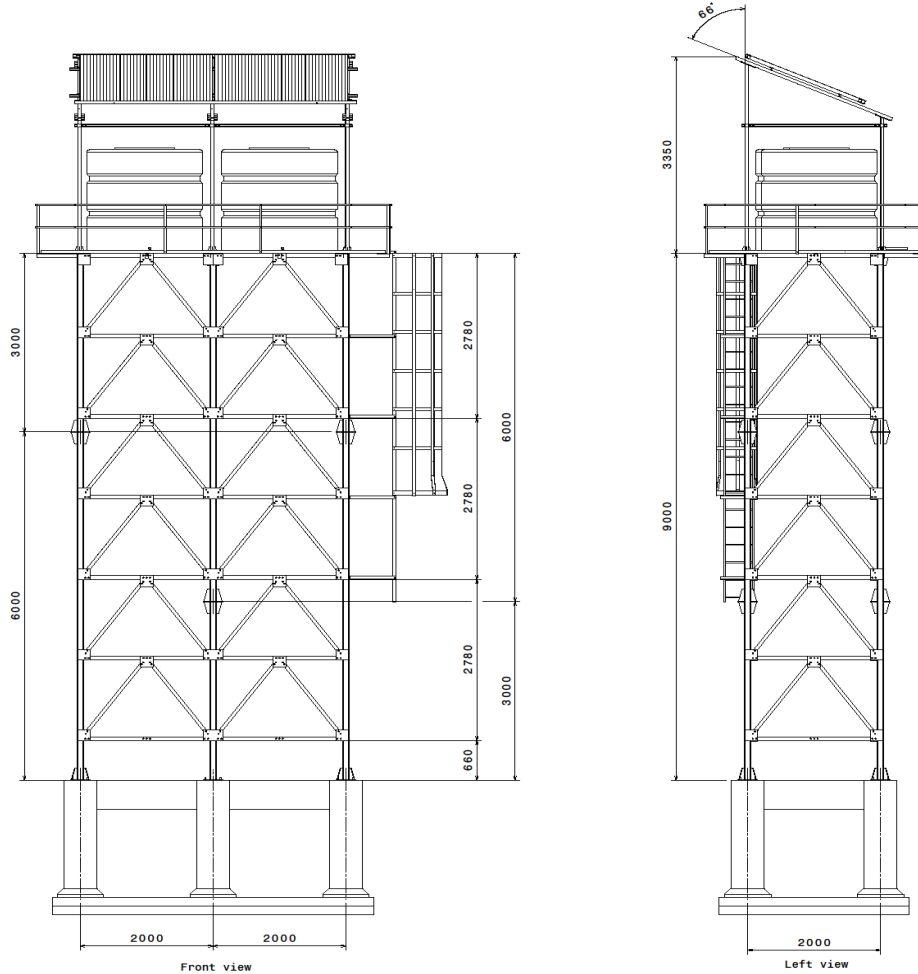

ALL DIMENSIONS ARE IN MM

CHATTISGARH STATE RENEWABLE  
ENERGY DEVELOPMENT AGENCY (CREDA)

PROJECT TITLE :

9 MTR SOLAR WATER TANK STRUCTURE

Drawn By	ARUN	13-06-2020	SCALE: NTS	TITLE:	9 MTR SOLAR WATER TANK STRUCTURE
Checked By			projection	Drwg No.	SHEET NO. 1 OF 1
Designed By				CREDA - 001	REV - 00

(2)

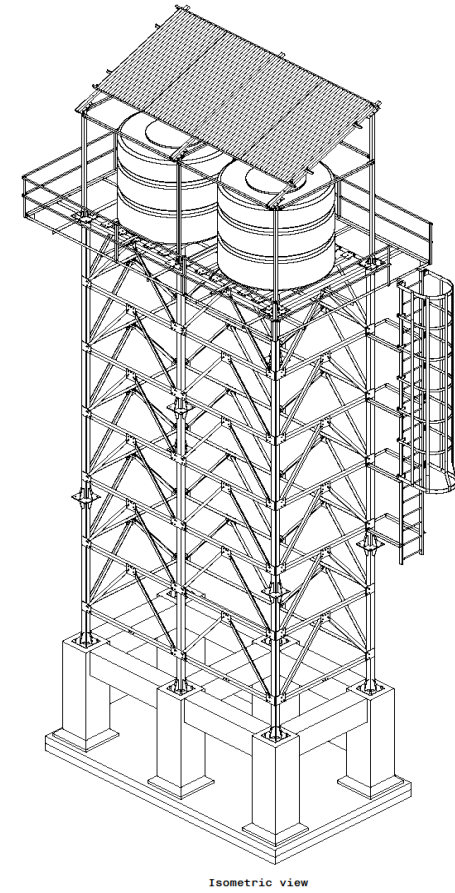
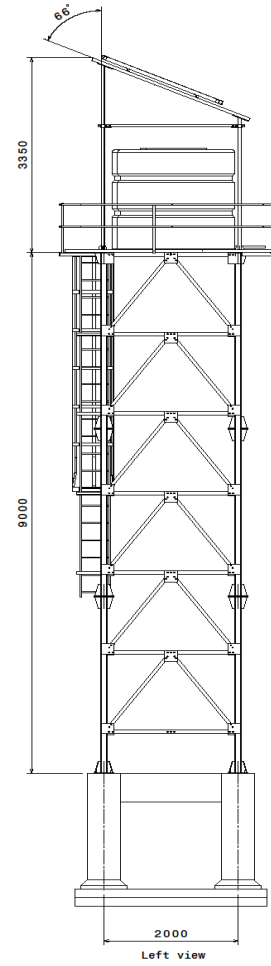
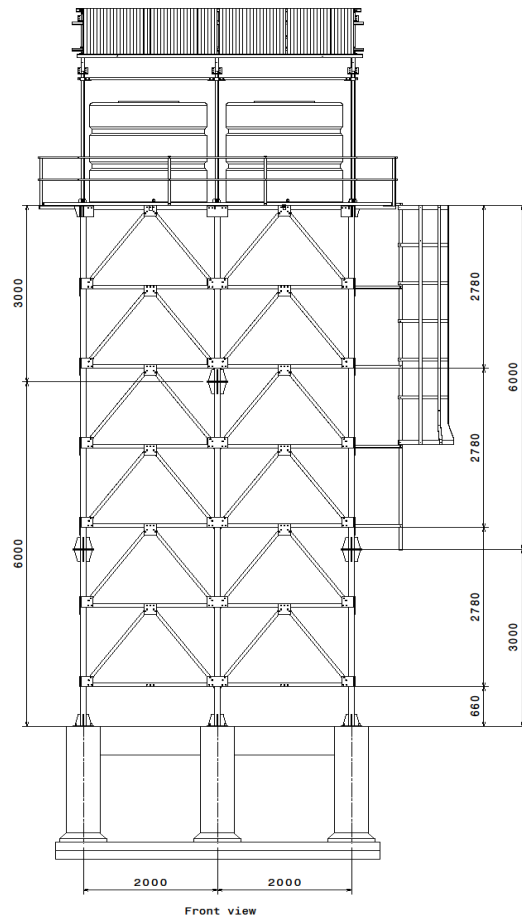

(3)

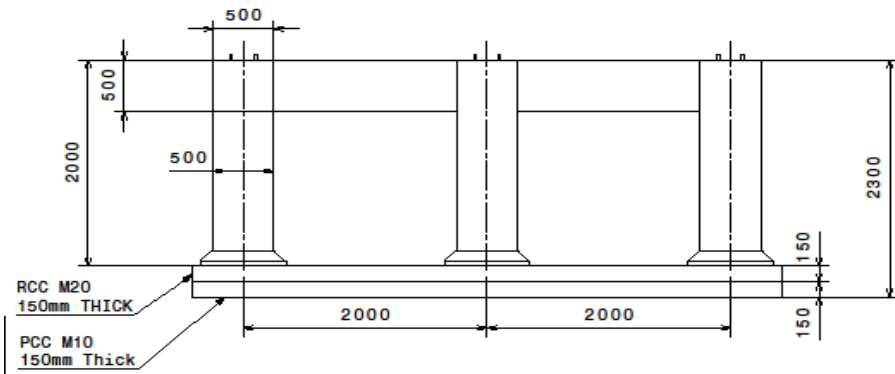

Front view

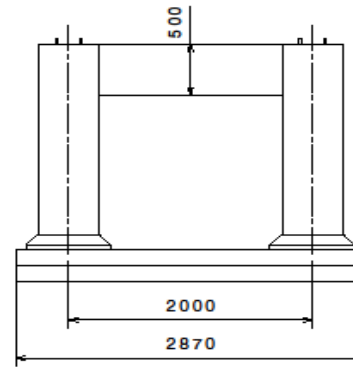

Left view

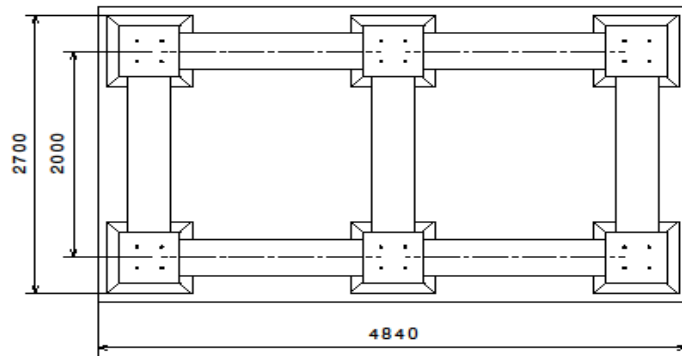

Top view

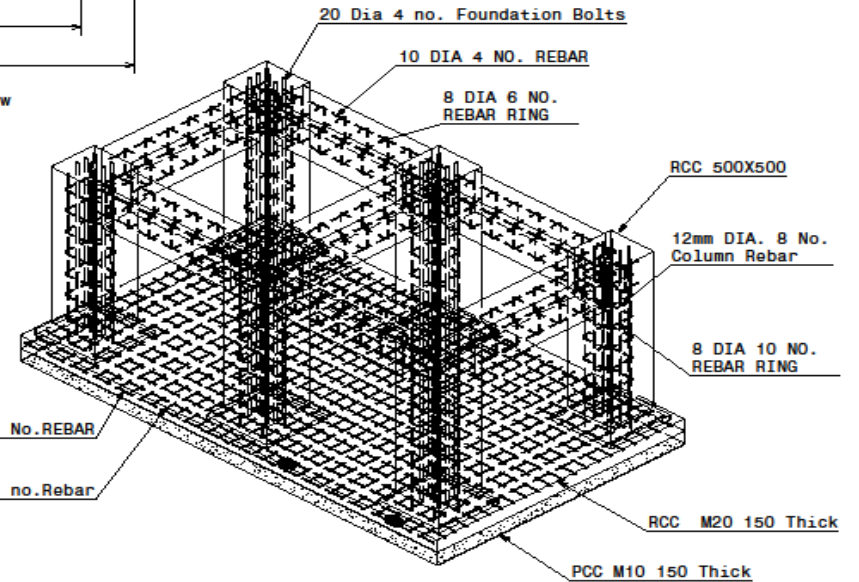

Isometric view

ALL DIMENSIONS ARE IN MM

CHATTISGARH STATE RENEWABLE ENERGY DEVELOPMENT AGENCY (CREDA)

PROJECT TITLE : 9 MTR SOLAR WATER TANK STRUCTURE					
Drawn By	ANIL	03-05-2019	SCALE: -NTS	TITLE:	9 MTR SOLAR WATER TANK STRUCTURE
Checked By			projection	Org No.	CREDA - 001
Designed By					REV - 00

Sheet No. 1 of 1  
REV - 00

(4)

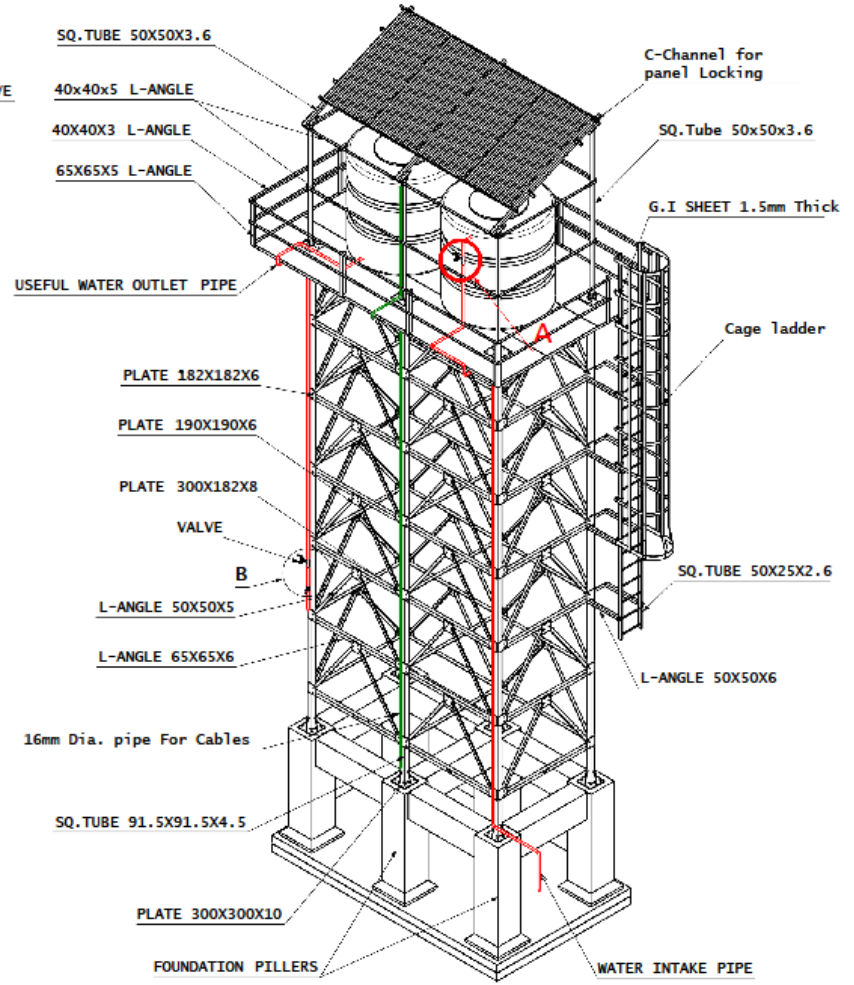
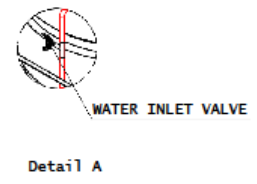
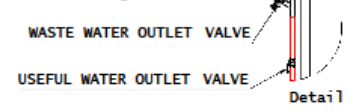
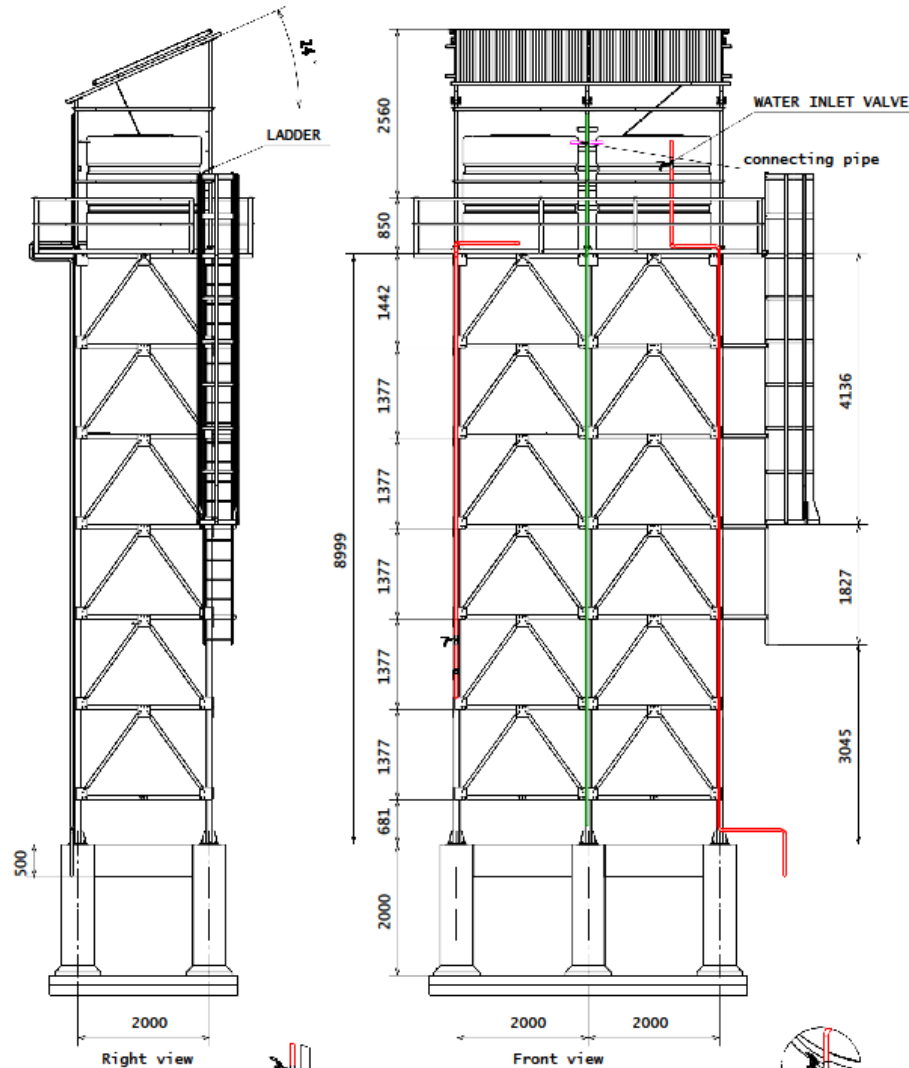

ALL DIMENSIONS ARE IN MM

<b>CHATTISGARH STATE RENEWABLE ENERGY DEVELOPMENT AGENCY (CREDA)</b>			
PROJECT TITLE : 9 MTR SOLAR WATER TANK STRUCTURE			
Drawn By	ANIL 03-05-2019	SCALE:-NTS	TITLE: 9 MTR SOLAR WATER TANK STRUCTURE
Checked By		projection	Drw No. CREDA - 001
Designed By			SHEET No. 1 OF 1 REV - 00

(5)

### TANK TOWER 9MTR. STRUCTURE 9MTR.

1000Lit (5000x2)

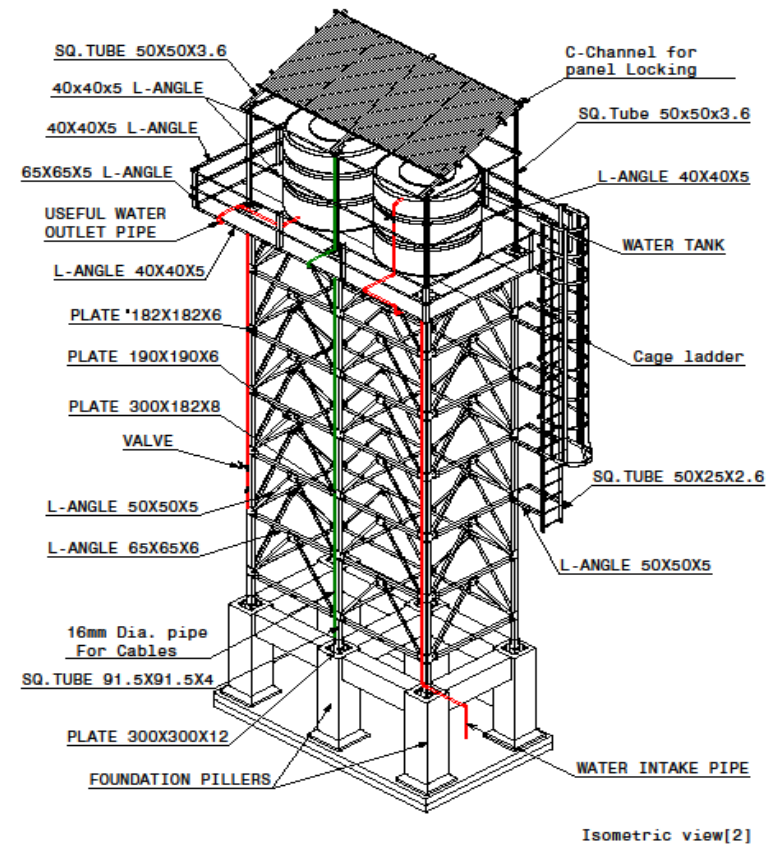
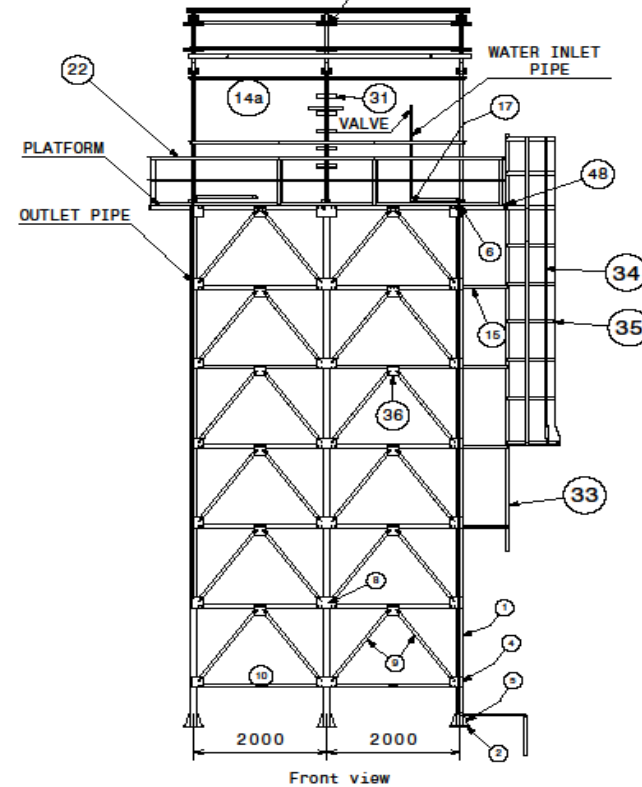
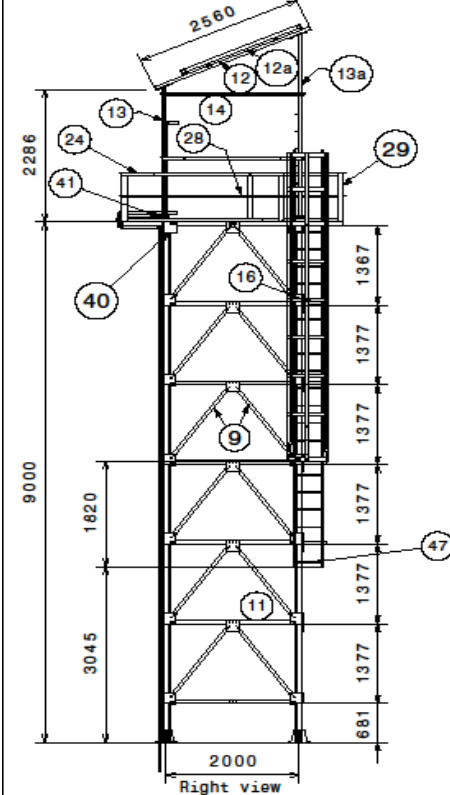
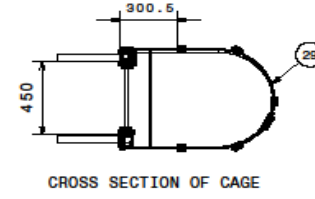
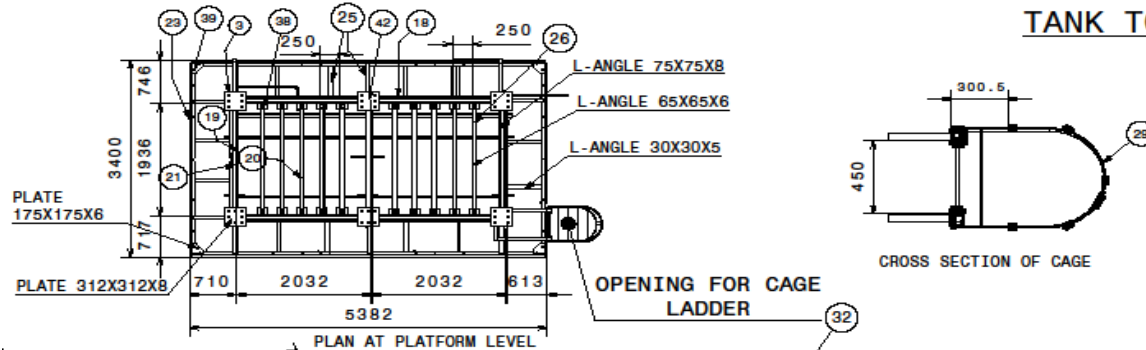

ALL DIMENSIONS ARE IN MM

CHATTISGARH STATE RENEWABLE ENERGY DEVELOPMENT AGENCY (CREDA)

PROJECT TITLE : 9 MTR SOLAR WATER TANK STRUCTURE			
Drawn By	ANIL	03-05-2019	SCALE: MTS
Checked By			projection
Designed By			
TITLE: 9 MTR SOLAR WATER TANK STRUCTURE			Brig No.
CREDA - 001			REV - 00

(6)

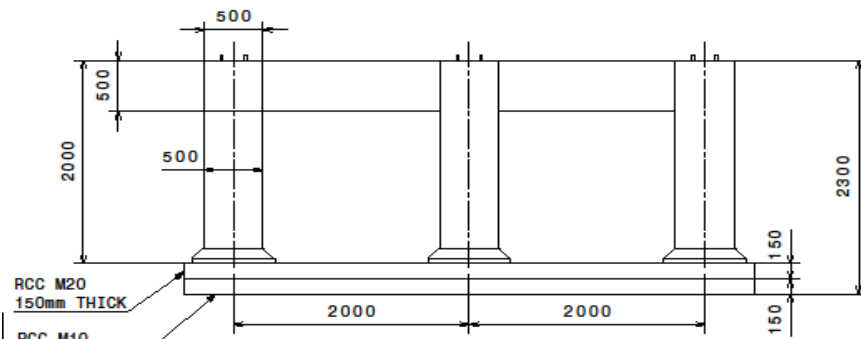

Front view

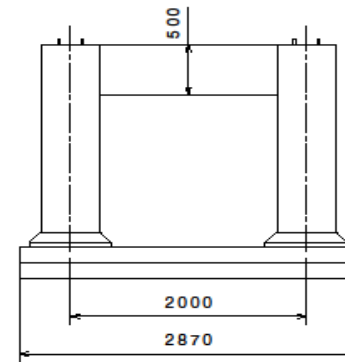

Left view

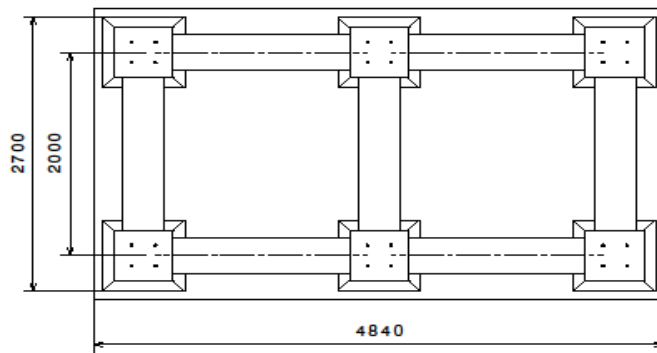

Top view

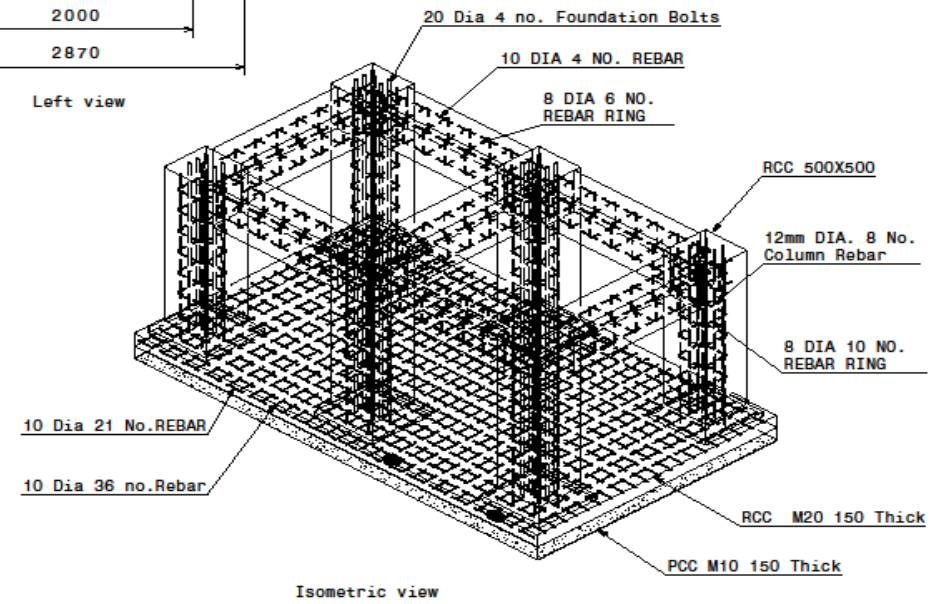

Isometric view

ALL DIMENSIONS ARE IN MM

CHATTISGARH STATE RENEWABLE ENERGY DEVELOPMENT AGENCY (CREDA)

PROJECT TITLE :				9 MTR SOLAR WATER TANK STRUCTURE	
Drawn By	AMEL	03-05-2019	SCALE:-MTS	TITLE: 9 MTR SOLAR WATER TANK STRUCTURE	
Checked By				Drwg No.	SHEET NO. 1 OF 1
Designed By				CREDA - 001	REV - 00

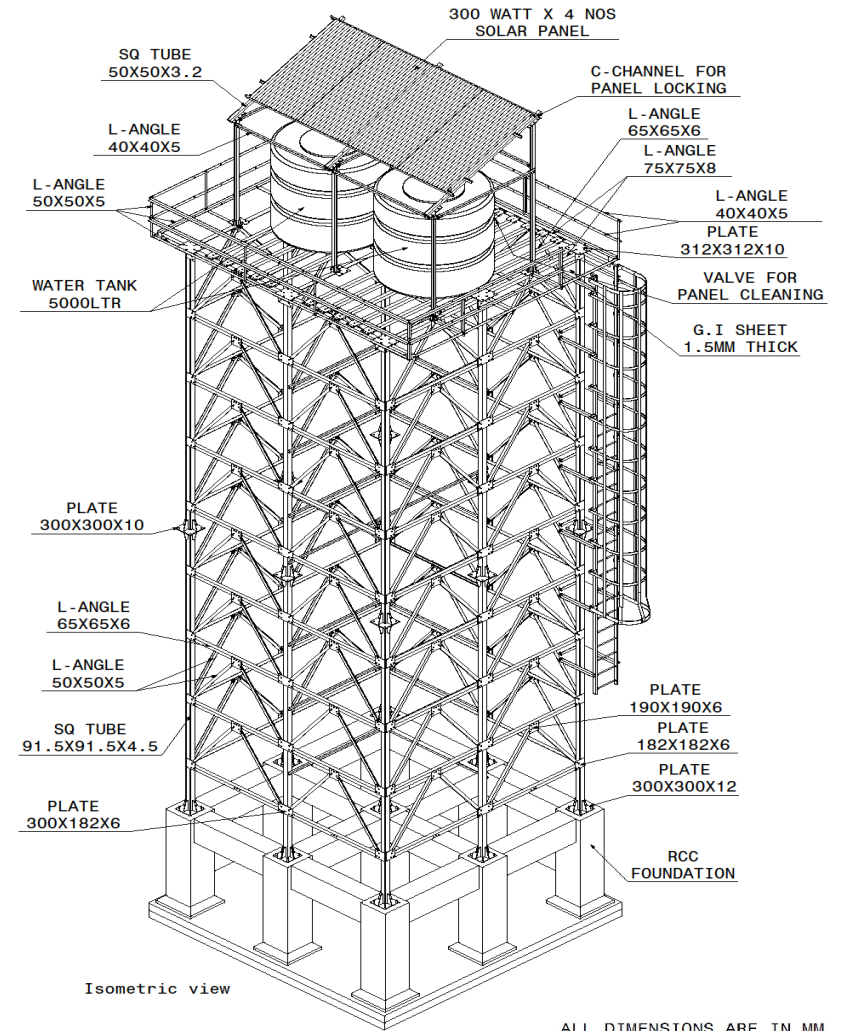
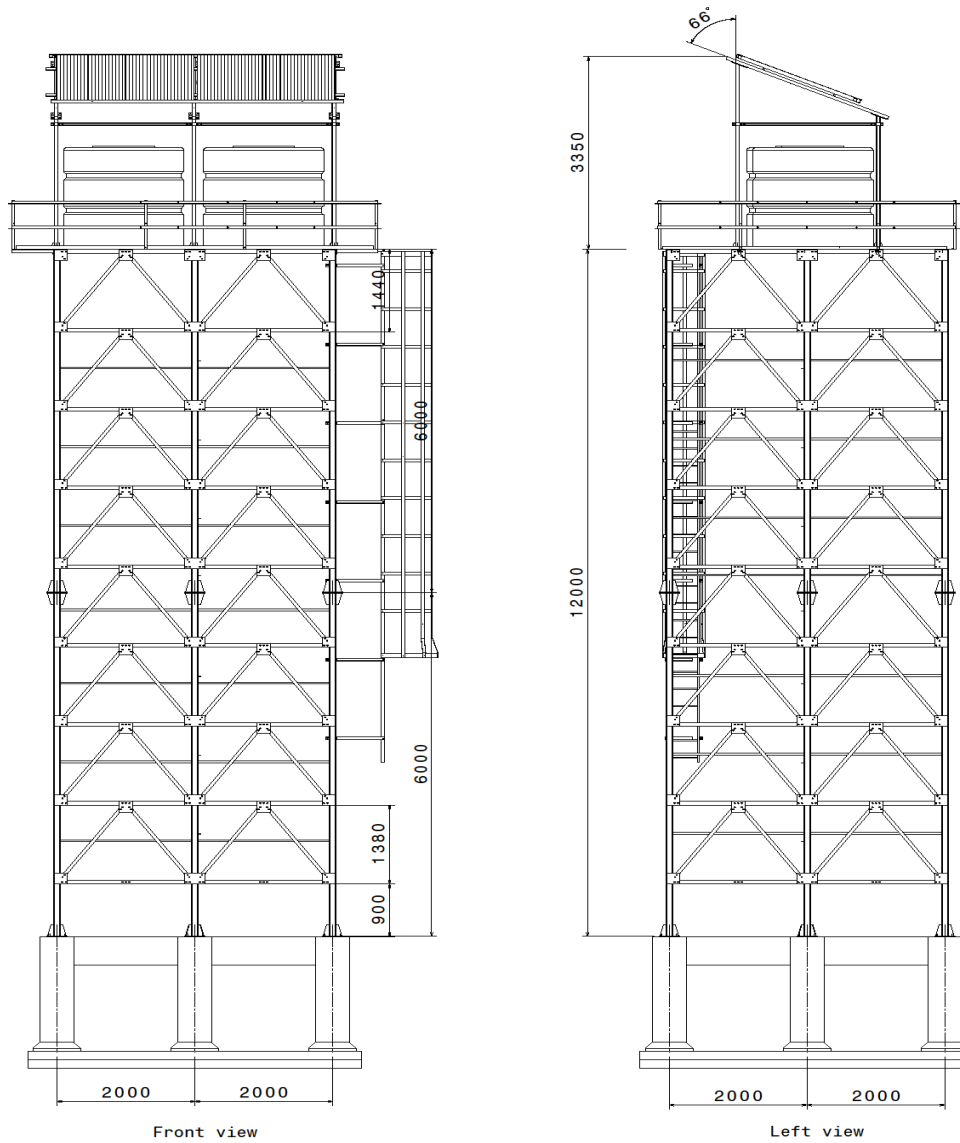

ALL FASTENERS OF GI TANK MOUNDING STRUCTURES SHALL BE GALVANISED OF 16MM

ALL DIMENSIONS ARE IN MM

CHATTISGARH STATE RENEWABLE ENERGY DEVELOPMENT AGENCY (CREDA)

PROJECT TITLE :		12 MTR SOLAR WATER TANK STRUCTURE	
Drawn by :	ANB	SCALE :	AS IS
Checked by :		TITLE :	12 MTR SOLAR WATER TANK STRUCTURE
Designed by :	projection	Fig. No. :	
CREDA - 001			Sheet No. 1 of 1
			REV - 00



(8)

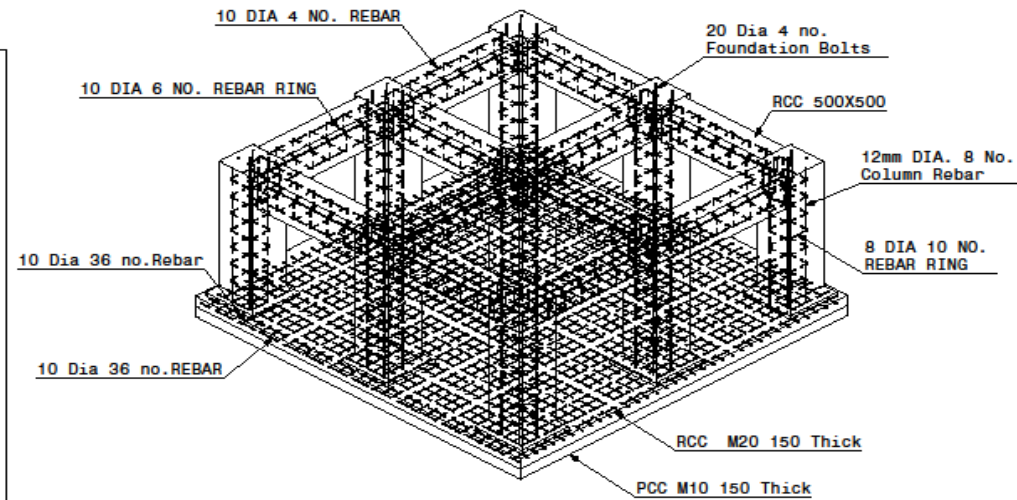
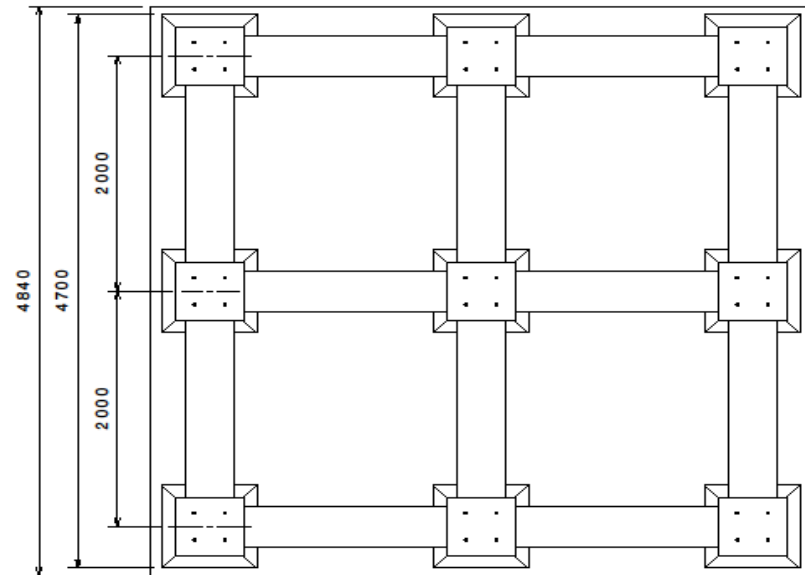
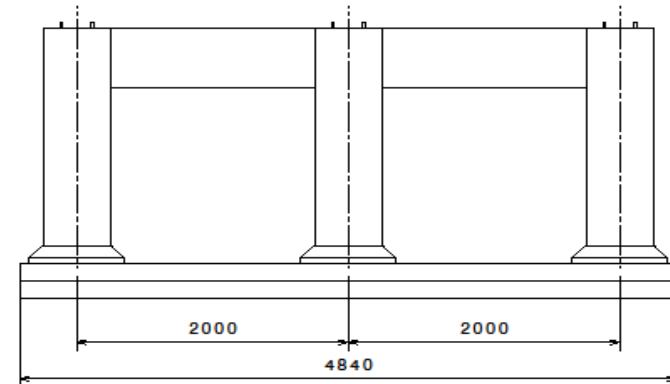
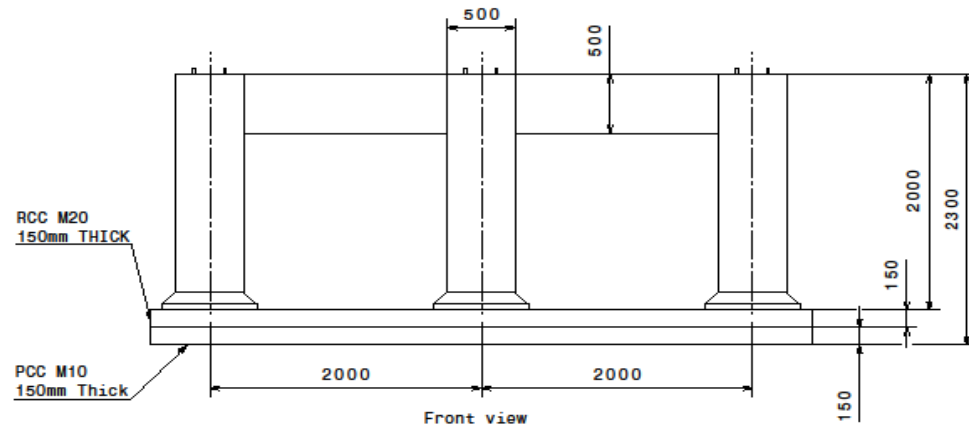

ALL DIMENSIONS ARE IN MM

CHATTISGARH STATE RENEWABLE  
ENERGY DEVELOPMENT AGENCY (CREDA)

PROJECT TITLE :		12 MTR SOLAR WATER TANK STRUCTURE	
Drawn By	ASUN	13-06-2020	SCALE:- NTS
Checked By			projection
Designed By			
TITLE: 12 MTR SOLAR WATER TANK STRUCTURE			Drwg No.
CREDA - 001			SHEET NO. 1 OF 1
			REV - 00